

REVISIONS			
REV	DESCRIPTION	DATE	APPROVED
1	INITIAL RELEASE PER ECO 21-28200	12/16/21	K.DUBROWN
A	RELEASE TO PRODUCTION PER ECO 22-29059	09/29/22	K.DUBROWN

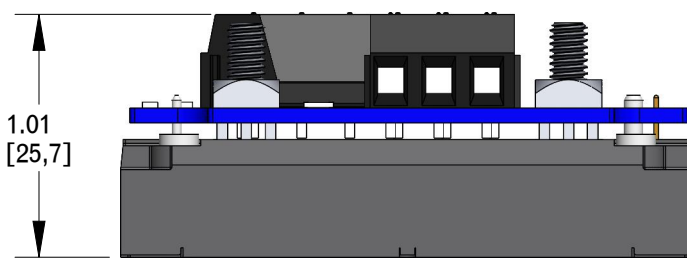
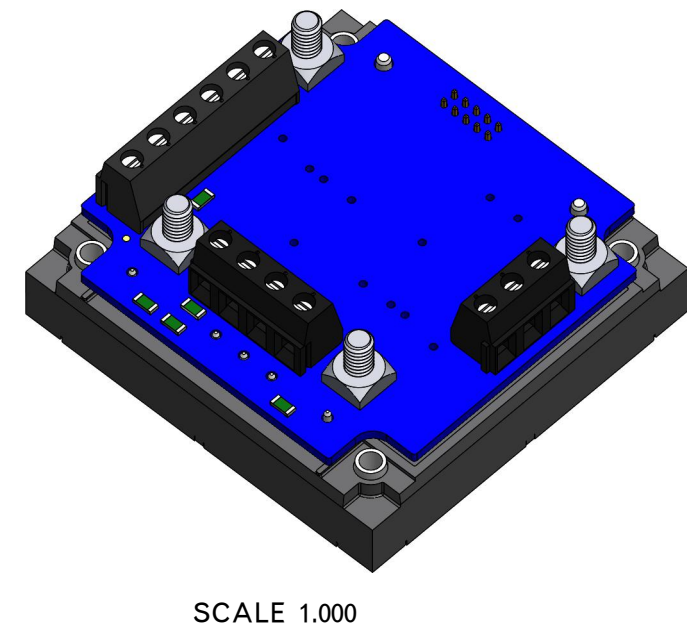
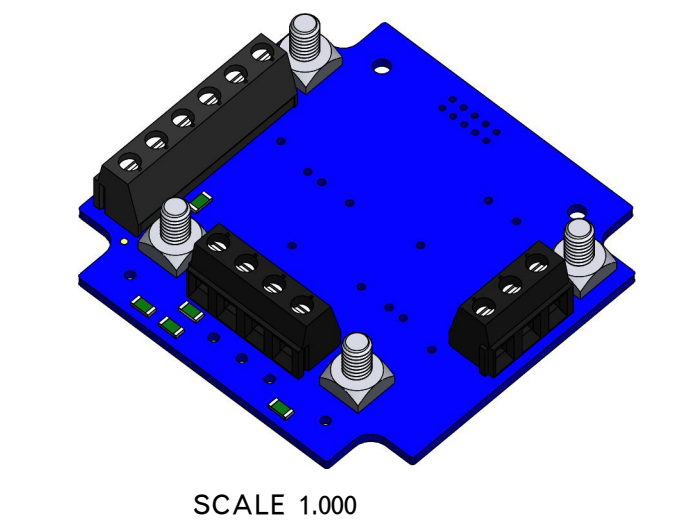
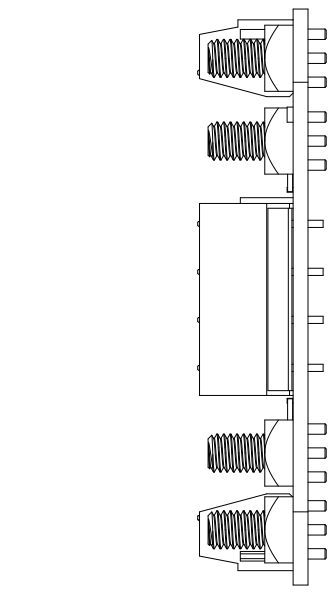

- NOTES:**
- CONSULT DATASHEET OF THE UNIT THAT THE INTERFACE BOARD IS / WILL BE MOUNTED TO FOR I/O DEFINITIONS, MOUNTING DIMENSIONS AND OPERATING PARAMETERS.
 - ALL DIMENSIONS IN INCHES (mm)
TOLERANCES: X.XX ± 0.02 IN. (X.X ± 0.5 mm)
X.XXX ± 0.010 IN. (X.XX ± 0.25 mm)
 - TERMINALS 3, 4, 5, 7: M4 SCREW POST, MAX TORQUE 6 IN-LB (0.7 Nm).
 - TERMINAL BLOCKS: WIRE SIZE 16-30 AWG, 13.5A MAX CURRENT PER TERMINAL, MAX TORQUE 4 IN-LB (0.5 Nm)
 - FITS THREADED, NON-THREADED AND FLANGED MCOTS-C-270-XX-HE HALF BRICKS
 - ADAPTOR WEIGHT: 1.06 oz (30 g)
 - ROHS COMPLIANT

TOLERANCES:
UNLESS OTHERWISE SPECIFIED:
ALL DIMENSIONS IN INCHES
.X +/- 0.025
.XX +/- 0.010
.XXX +/- 0.005
ANGLES +/- 1°

THIRD ANGLE PROJECTION

THIS DRAWING IS THE PROPERTY OF SYNQOR INC. IT IS NOT TO BE REPRODUCED OR COPIED, IN WHOLE OR IN PART, OR USED FOR FURNISHING INFORMATION TO OTHERS, OR FOR ANY PURPOSE DETRIMENTAL TO THE INTERESTS OF SYNQOR. THE INFORMATION SHOWN HEREIN MAY BE PROTECTED BY PATENTS OWNED OR CONTROLLED BY SYNQOR

SynQor 155 SWANSON ROAD
BOXBOROUGH, MA 01719-1316

**HBI-10 INTERFACE ADAPTER ASSEMBLY
MECHANICAL OUTLINE DRAWING**

SOURCE: PRO/E 020-0000404_A

SIZE	DATE	DWG. NO.	REV
B	SEP-29-22	020-0000404	A

SCALE: 1.250 DRAWN: KJD CHECK: SHEET 1 of 1